



Handgabelhubwagen **AM 22 SH / 22 NH**

Hubhöhe: 122 mm / Tragfähigkeit: 2200 kg

 **JUNGHEINRICH**

AM 22 SH / 22 NH

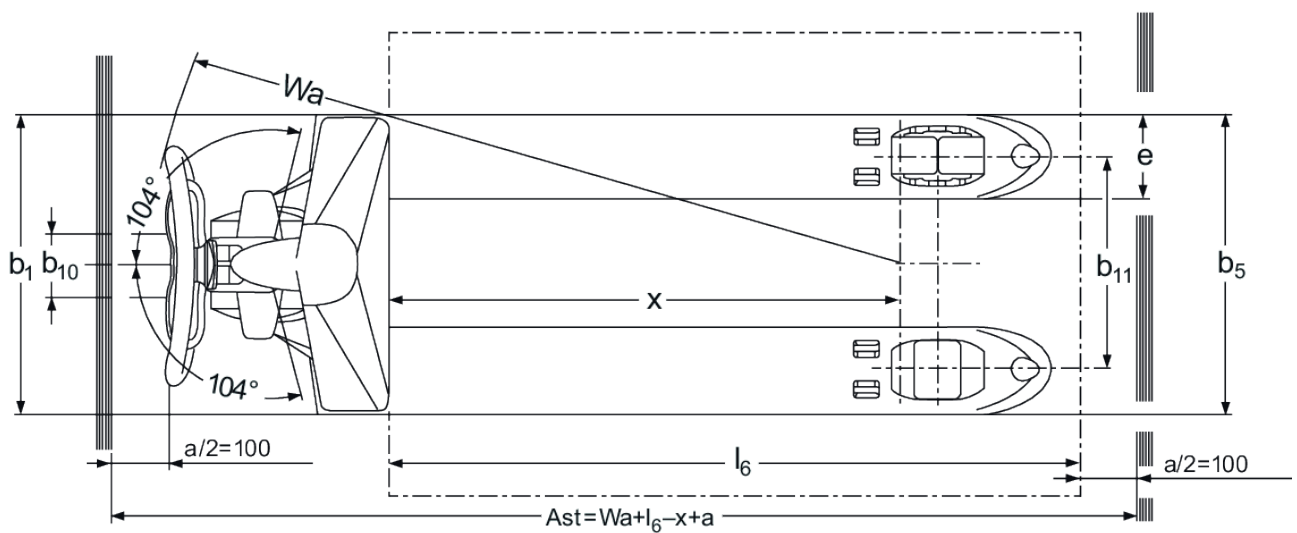
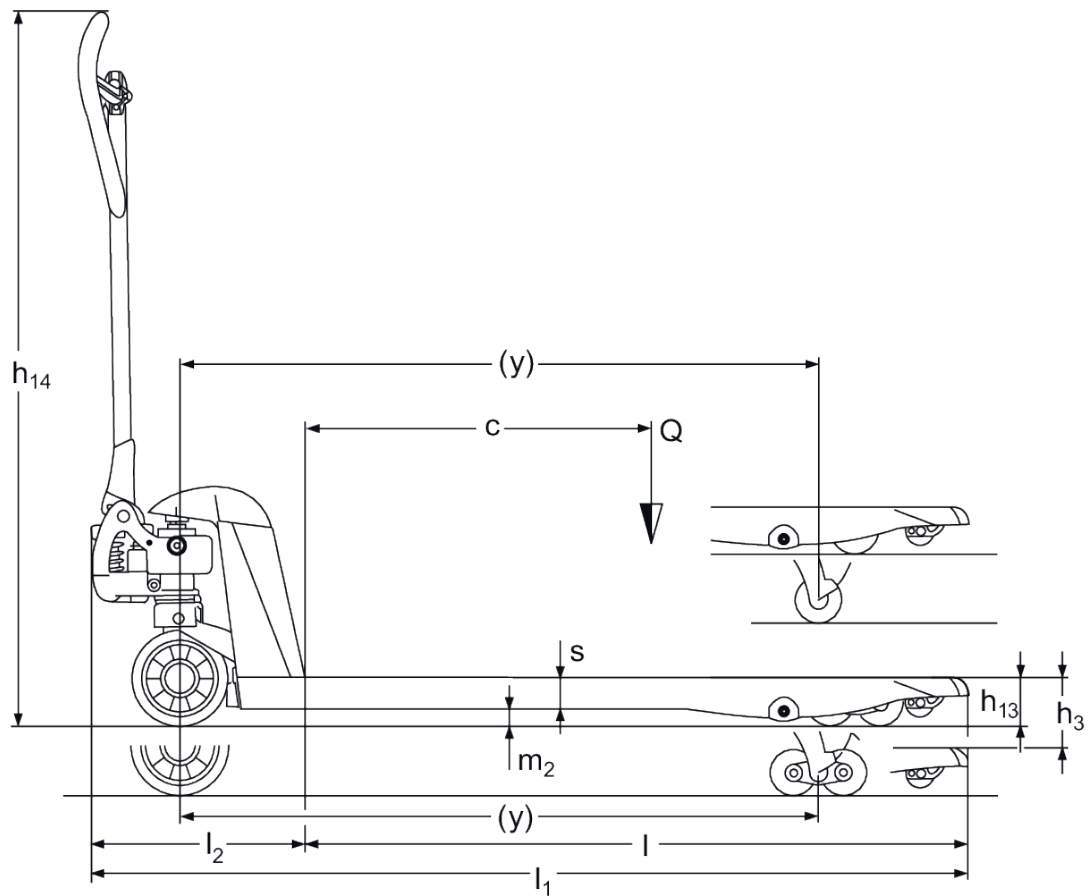

VDI-Tabelle

Stand: 05/2021

Kennzeichen	1.1	Hersteller (Kurzbezeichnung)																						
	1.2	Typzeichen des Herstellers		AM 22 NH																				
	1.3	Antrieb																						
	1.4	Bedienung																						
	1.5	Tragfähigkeit/Last	Q kg																					
	1.6	Lastschwerpunktabstand	c mm	300	400	450	500	550	600	300	400	450	500	550	600	300	400	450	500					
	1.9	Radstand	y mm	560	755	862	1014		1110		560	755	862	910	1014		1110	560	755	862	910			
Gewichte	2.1	Eigengewicht	kg	50	51	53	56	60	61	50	52	53	56	60	61	50	51	53	56					
	2.3	Achslast ohne Last vorn/ hinten	kg	-																				
Räder/Fahrwerk	3.1	Bereifung																						
	3.2	Reifengröße, vorn																						
	3.3	Reifengröße, hinten																						
	3.5	Räder, Anzahl vorn/ hinten (x=angetrieben)		2/2														2/2						
	3.6	Spurweite, vorn	b ₁₀ mm	109	-	109	-																	
	3.7	Spurweite, hinten	b ₁₁ mm	370	-	370	-																	
Grundabmessungen	4.4	Hub (h ₃)	h ₃ mm																					
	4.14	Standhöhe angehoben	h ₁₂ mm																					
	4.15	Höhe gesenkt	h ₁₃ mm																					
	4.19	Gesamtlänge	l ₁ mm	973	1168	1275	1427	1523	973	1168	1275	1323	1427	1523	973	1165	1275	1323						
	4.20	Länge einschließlich Gabelrücken	l ₂ mm	373											-									
	4.21.1	Gesamtbreite	b ₁ mm	520					-															
	4.22	Gabelzinkenmaße	s/ e/l x	53 x 150 x 600	53 x 150 x 795	53 x 150 x 902	53 x 150 x 950	53 x 150 x 1054	53 x 150 x 1150	53 x 150 x 1207	53 x 150 x 600	53 x 150 x 795	53 x 150 x 902	53 x 150 x 950	53 x 150 x 1054	53 x 150 x 1150	53 x 150 x 1207	53 x 150 x 600	53 x 150 x 795	53 x 150 x 902	53 x 150 x 950			
	4.25	Gabelaußenabstand	b ₅ mm																					
	4.32	Bodenfreiheit Mitte Radstand	m ₂ mm																					
	4.34	Arbeitsgangbreite (Palette 1000x1200 quer)	Ast mm	1584			1627			1734			1584			1627			1734			1584		
	4.34.1	Arbeitsgangbreite (Palette 800x1200 längs)	Ast mm	1784			1773			1784														
	4.35	Wenderadius	W _a mm	724	919	1026	1178		1274		724	919	1026	1074	1178	1274	724	919	1026	1074				
Leistungsdaten	5.3	Senkgeschwindigkeit mit/ohne Last	m/s	0,09 / 0,02				-																

- Dieses Typenblatt nach VDI-Richtlinie 2198 nennt nur die technischen Werte des Standard-Gerätes. Abweichende Bereifungen, andere Hubgerüste, Zusatzeinrichtung

Zertifiziert sind die deutschen
Produktionswerke in Norderstedt,
Moosburg und Landsberg.

ISO 9001
ISO 14001

Jungheinrich Flurförderzeuge
entsprechen den europäischen
Sicherheitsanforderungen.



 **JUNGHEINRICH**